



---

PRODUCT COLLECTION

# H A G E N H I N D E R D A E L

Pairing product design with art, HagenHinderdael are an award-winning creative practice who work at the intersect of sustainable design and innovative technology to create 3D printed sculptural products and immersive installations.

Merging recycled materials with traditional craftsmanship and cutting-edge technology, the designers Lisa Hinderdael and Sofia Hagen produce elements, feature installations, and placemaking schemes that push the boundaries of engineering whilst bearing the incentive of a continuous afterlife.

As a creative practice, beyond their conceptual visions they are also fundamentally grounded in how to be earth-conscious designers of the future: always designing with the ethos of a circular economy in mind. From the business vision where all installations are made up of products to allow for repurposing and scalability, to their research and development arm into how to integrate the latest technologies within their designs: HagenHinderdael aim to inspire future generations into what we can do when we think outside of the box and bring our narrative full circle.







M







# CONTOUR

**Contour was exhibited at the Vorarlberger Architektur Institut and at Rossana Orlandi Gallery during Milan Design Week 2022**

A collaboration between London-based designers HagenHinderdael and Austrian 3D printed concrete specialists Concrete3D, CONTOUR is a new bench combining environmentally friendly printing technology with bespoke design. Launching in March 2022 at the Vorarlberger Architektur Institut, the feature bench has been developed with sustainability and its local context in mind.

In its form, CONTOUR takes inspiration from the surrounding landscape of Vorarlberg. Organic curvatures are printed layer by layer to reveal the topographical layers of the mountainscapes coupled together to form the seat. This design language continues into the elevation of the bench itself, as it mimics the peaks and troughs of the skyline of Vorarlberg.

Available in two sizes, CONTOUR S and CONTOUR L can nestle into one another – with the negative space between them creating further dynamic dialogues amongst the furniture set. This playful character of the benches is further elevated in the graphic colouring used in the print itself which uses a unique algorithm to print varying gradients of grey resulting in a bespoke finish every time.



# CONTOUR

**Material:** 3D Printed Concrete

**Lead Time :** 10-12 weeks

**Dimensions & Weight :**

S : 88cm (l) x 36cm (w) x 25-35cm (h), 50kg

L : 110cm (l) x 40cm (w) x 40-66cm (h), 135kg

**Finish:** Gradient Grey, Red, Yellow, Green

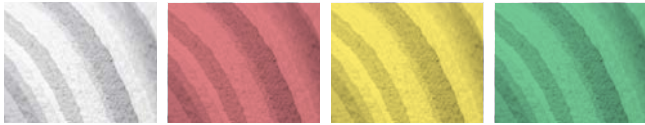

Elevation Large

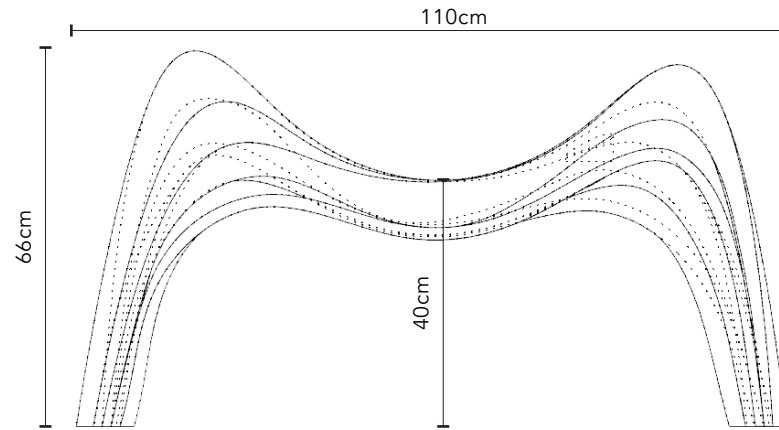

Elevation Small

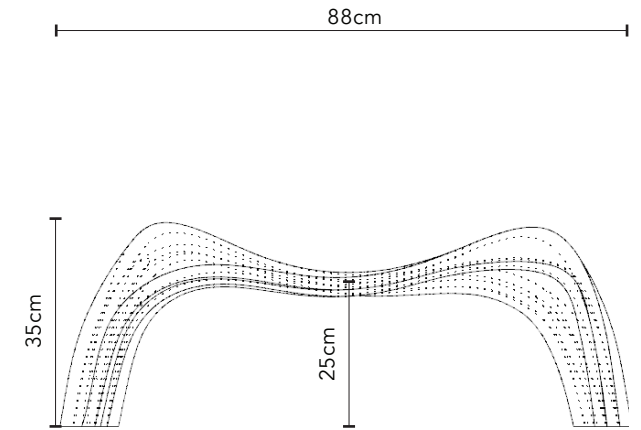

Plan Large

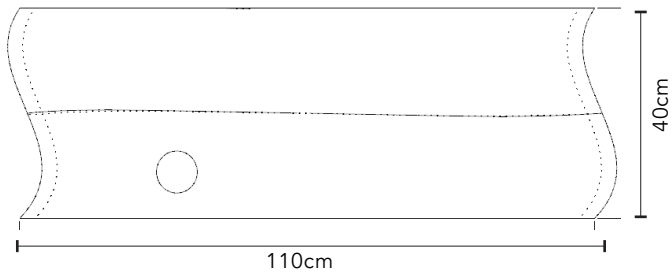

Plan Small

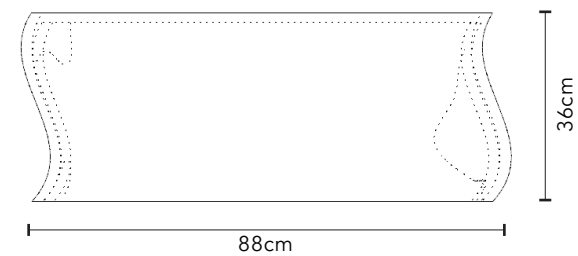





# K O F I K A

## **Kofika is Finalist in Rossana Orlandi Gallery's Guiltless Plastic Prize, Milan Design Week 2023**

A collaboration between London-based designers HagenHinderdael and material laboratory Novavita Design, KOFIKA is a collection of two coffee tables that celebrate duality and invite its users to enjoy all things COFFEE. Pairing product design with art, HagenHinderdael x Novavita Design bring together the latest in innovative 3d printing technologies and a material research laboratory to create a timeless design embedded in the Italian everyday coffee drinking culture.

Each table is a sculptural yet playful dialogue that reincarnates coffee, milk, sugar, and plastic whilst cleaning up the planet.

Drawing inspiration from the Italian architectural colonnades and marble of the past, the materiality and form of KOFIKA brings together traditional, iconic Italian design language into 21 st century design. Our tabletops are made of plastic sheets constructed from recycled coffee and milk packaging waste. These are then rested on 3D printed legs that are made from a unique fermented sugar cane bio-PLA mixture.

As an object, KOFIKA is inspired by the Italian allure of past and present – from the coffee drinking culture where people sprawl into espresso bars through to the classic Italian architectural forms seen in romantic colonnades and ancient ruins.





# K O F I K A

**Material:** 3D Printed bio-PLA from sugar cane, recycled coffee and milk packaging

**Lead Time :** 10-12 weeks

**Dimensions & Weight :**

S : 38cm (dia) x 35cm (h), 4kg

L : 40cm (dia) x 65cm (h), 7kg

**Finish:** Off-White, Dark brown marble effect

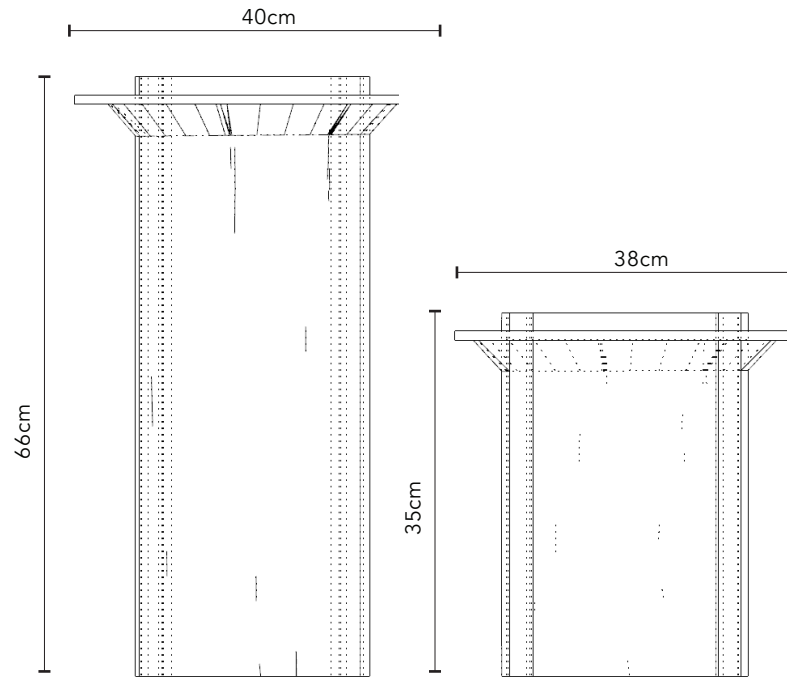
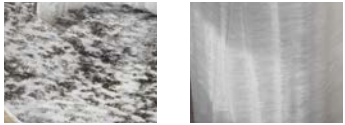

Elevation Large

Elevation Small

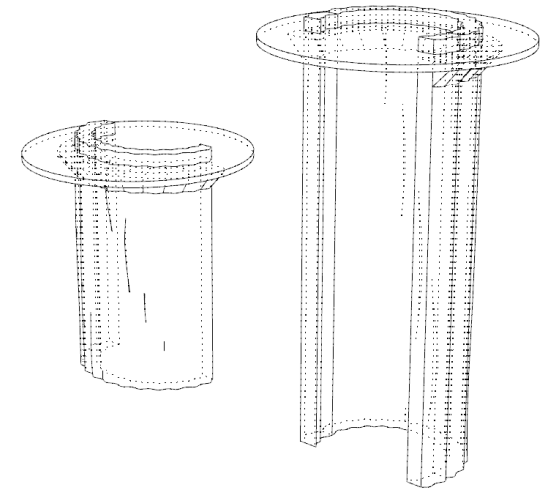

Plan View

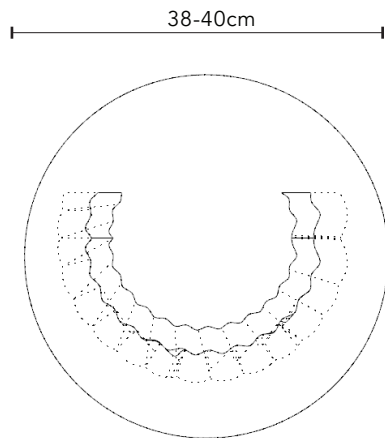



SWIVEL



# SWIVEL

**Launched at the Material Matters Show during London Design Festival 2022**

A collaboration between London-based designers HagenHinderdael and digital fabrication specialists Fab.Pub, SWIVEL is a dual purpose stool and planter combining environmentally friendly printing technology with bespoke design.

Made of 3D printed fermented sugar and wood fibre, SWIVEL can be flipped upside down depending on its function. Its natural, organic curves invite the user to rotate and engage with it in a playful manner.

Swivel is 3D printed with PLA bioplastic, which is 80% more carbon efficient than conventional plastic. A cradle to cradle material, the source waste used in the production is in line with the principles of the circular economy.



# SWIVEL

**Material:** 3D Printed Sugar & Wood Fibre

**Lead Time :** 10-12 weeks

**Dimensions:**

S : 30cm (l) x 25cm (w) x 45cm (h)

L : 40cm (l) x 35cm (w) x 45cm (h)

**Finish:** Natural wood fibre



Elevation 1

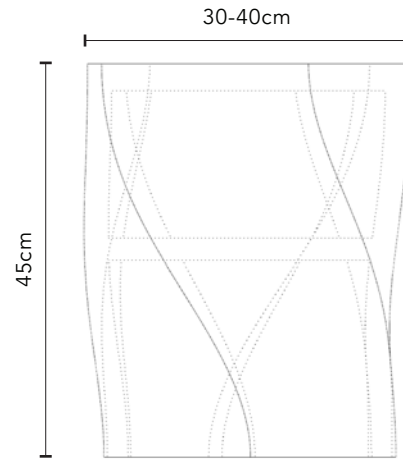

Elevation 2

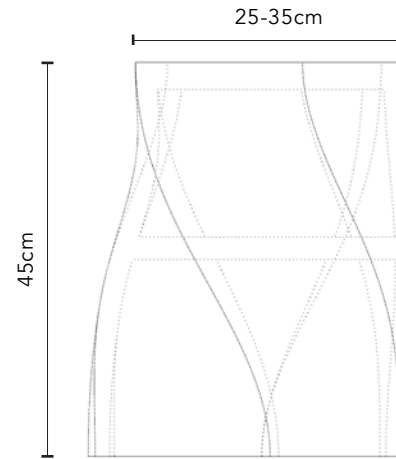

Elevation 3

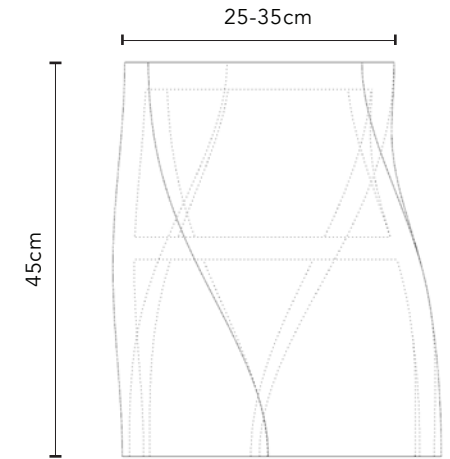

Plan

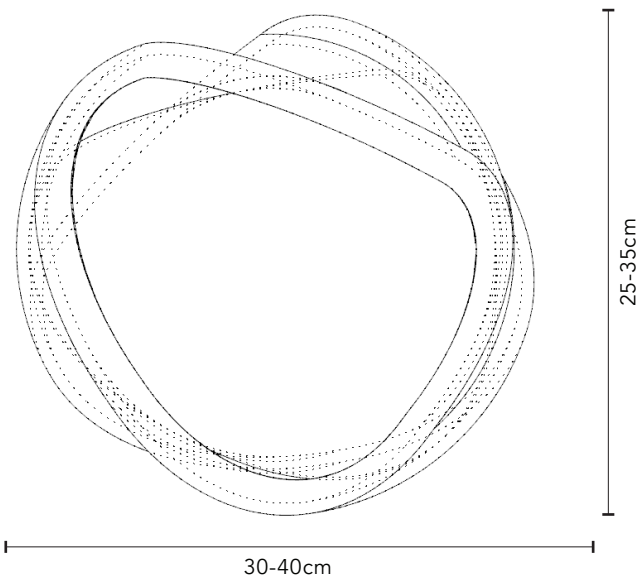



TWINE



Twine, 2017  
Material: 3D-gedrucktes, modulares Kunststoff

Kinder- und Jugendbücher

Angewandte und bildende Kunst

# T W I N E

**Finalist at Rossana Orlandi Guiltless Plastic Prize,  
Milan Design Week 2021**

**Twine** is a modular outdoor furniture series encouraging dynamic interaction through combining individual segments into a streamlined flow.

Developed in collaboration with Amsterdam-based material scientists Reflow, and London based robotic fabrication specialists, AI Build, Twine takes medicinal tray waste turned into r-PETG filament and transforms it through robotic manufacturing. Built atop a unique mould, the robots can carry up to two varying filaments creating a gradient of transparencies within the elements.

Available as a seat or an elongated bench, the sculptural form of Twine has been driven by the concept of merging sustainable technologies with play and interaction. We invite users to assemble the elements as individual components or flip and combine them into longer configurations providing new discoveries at every turn.



# T W I N E

**Material :** r-PETG from Medicinal Tray Waste

**Lead Time :** 10-12 weeks

**Dimensions:**

Small: 106cm (l) x 30cm (w) x 50cm (h)

Large: 106cm (l) x 45cm (w) x 50cm (h)

**Finishes:**

Arctic Breeze, Seafoam Green, Nautical Blue



Front Elevation

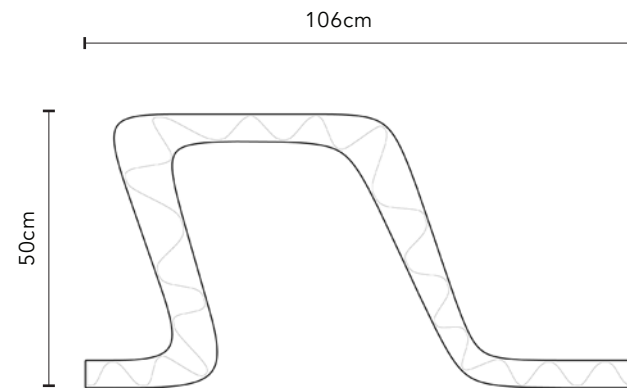

Side Elevation

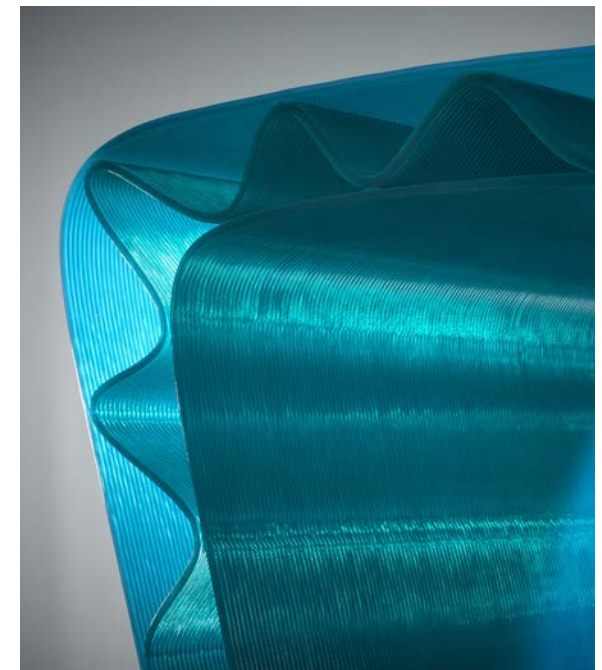
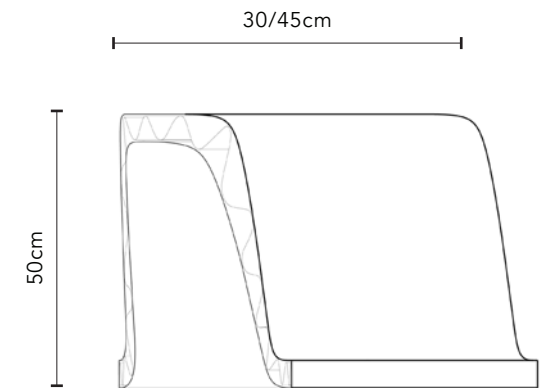



NACRE





# N A C R E

## Showcased at Dubai Design Week 2020

Nacre is a modular series of outdoor furniture and planters. A collaboration between London-based designers HagenHinderdael and Dubai-based 3D-printed concrete specialists Concreative, the seats were launched at Dubai Design Week 2020 and have been followed by a new series of planters launched in 2021 to complement public realm and outdoor environments.

Both the planter and the seats are available as a mix-and-match series of three heights. As seats, you can have a step, a stool, or a bar – each able to be complemented by a corresponding small, medium, or large planter.

The form of Nacre is constructed from hexagonal platelets that interlock, rotate, and penetrate. Together creating a structure of extraordinary strength and flexibility, that resembles the structure of the mother of pearl and speaks to the heart of Dubai's pearl trade. Each platelet is made of 3D printed concrete with intricate textures and optional integrated LED lighting. The result is a constellation of sculptural outdoor furniture & planting objects that allow for a variety of configurations.





# N A C R E

**Material :** 3D Printed Concrete

**Lead Time :** 12-16 Weeks

**Dimensions:**

Step: 32cm (h) x 45cm (l) x 55cm (w)

Stool: 65cm (h) x 45cm (l) x 55cm (w)

Bar: 96cm (h) x 45cm (l) x 55cm (w)

**Finishes:** Concrete and Powdercoated RAL Match

*\* bespoke finishes available on request*



Stool : 325mm



Step : 650mm



Bar : 960mm

**Planting:**

Optional addition for open top and lining to allow for use as a planter. Please enquire directly when placing your order.

*\* Note : Components of Nacre are produced in Dubai and will be crated to be delivered direct to final destination.*





# N A C R E . P

## Special Edition: bio PLA Stools

Inspired by the NACRE installation featured at Dubai Design Week in 2021, NACRE.P celebrates the latest in sustainable 3D printing using bio PLA from fermented sugar cane to create flexible and modular seating elements.

Made to order, the NACRE.P are able to be finished to match bespoke colours and durable for outdoor use due to their inherent UV and water-resistant qualities.

Developed in a series of striped and solid green finish, they will be featured at the NODE BRIXTON development launching in January 2023.





# N A C R E . P

**Material :** 3D printed bio PLA

**Lead Time :** 10 Weeks

**Dimensions:**

46cm (l) x 36cm (w) x 42cm (h)

**Finish:**

Moss Green Solid or Stripes, or RAL Matched

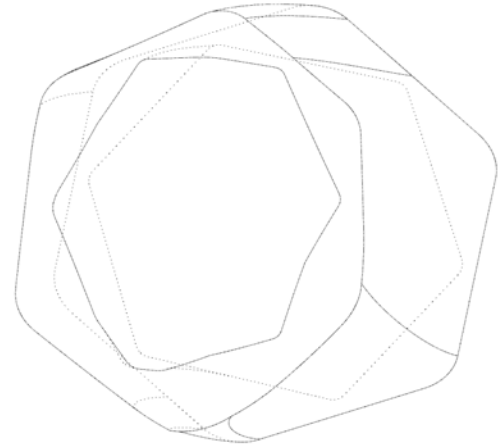
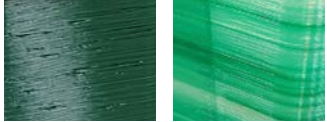

46cm

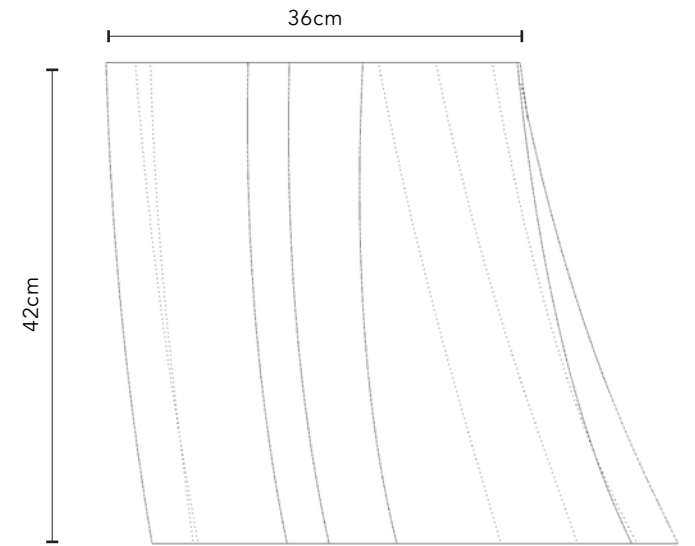

42cm

36cm

46cm

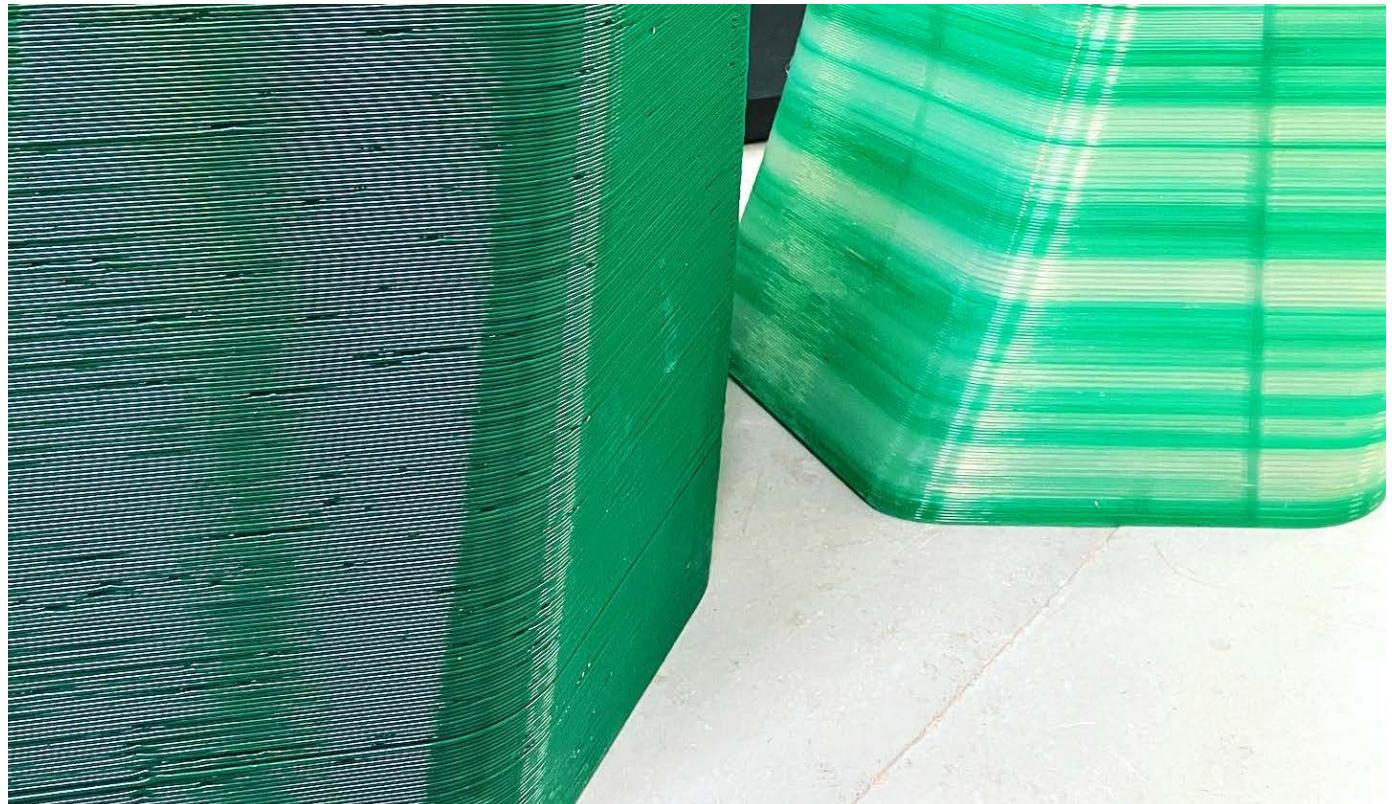





COCOON





# C O C O O N

## Dezeen Longlist, Sustainable Design, 2021

**Cocoon** is a 3D printed decorative lamp celebrating craft and pushing the boundaries of new and sustainable technologies by transforming wood waste into an organic, technologically advanced light.

The sculptural form of Cocoon has been developed to resemble an organic structure that speaks to the natural materials being used and creates an opportunity for beautiful protrusions to throw shadows from the integrated OLED light on to the surrounding surfaces. The shell itself is made of 3d printed sawdust and has been developed in collaboration with Forust, a US based company who manufacture with wood by using methods that are non-destructive to our planet's ecology.

Cocoon comes in two typologies each with their own unique shape. Using ground-breaking 3D printing technology, layers of powdered wood are bound together with lignin into a 250mm (w) x 460mm (h) Cocoon. Once out of the printer, each piece is carefully hand-stained and finished. In this process, there is also the opportunity to finish Cocoon in a wide variety of wood species including natural, oak, teak, and walnut.

Cocoon is not only beautiful in its aesthetic but forward-thinking in its lifecycle - able to avoid its materials ending up back in landfill and instead used in future light productions.



# C O C O O N

**Material :** 3D Printed Sawdust

**Lead Time :** 10-12 weeks

**Dimensions:**

25cm (w) x 46cm (h)

**Finish:** Walnut, Natural

\*Alternative finishes upon request



**Light Source:** OLED Panel

**Temperature :** 3000K

**Voltage:** 220-240v AC or 24v DC

**Brightness (Lumens) :** 200

**Dimmable :** No



HH

Type A - Top View, Left, Right, Front and Back

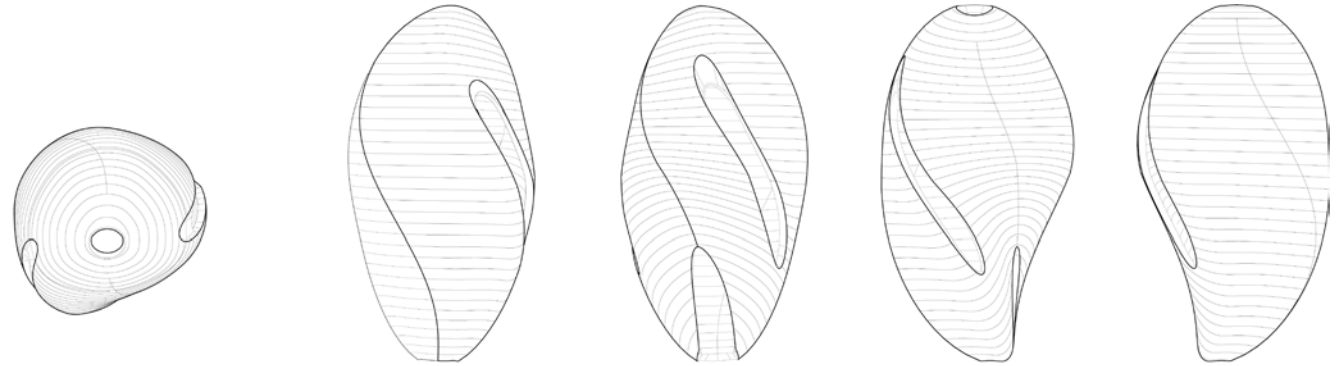

Type B - Top View, Left, Right, Front and Back

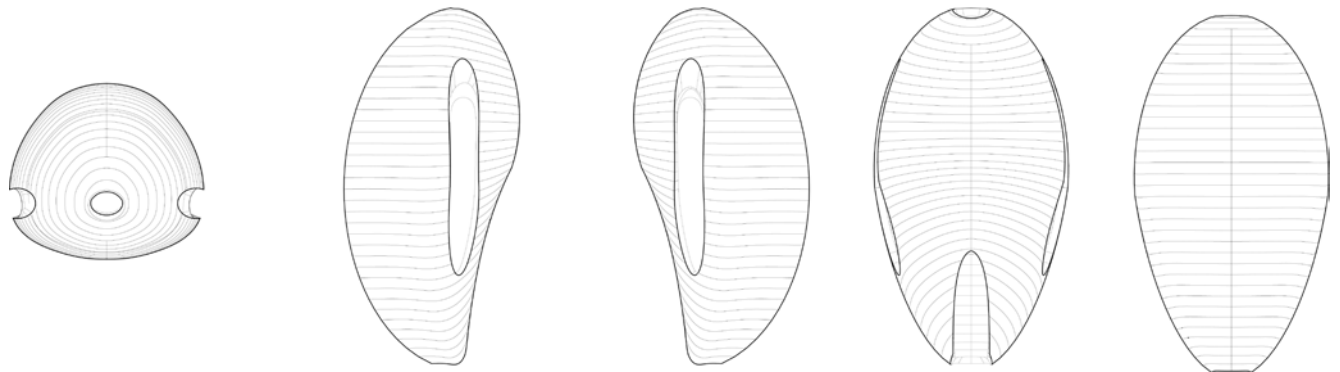



BOLLA





# B O L L A

**Bolla is winner of the LAMP Awards 2020 and Shortlisted for the DARC Awards 2020**

**Bolla** brings awareness to how the escalated use of packaging materials is affecting our environment. Pointing the way to a circular economy instead of designing things to fail, bubble wrap sourced from packaging waste is used as form-work and transformed through parametric modelling and innovative research into the light product Bolla.

Made of an eco-friendly concrete mixture that has been custom developed with material scientists, recycled plastic particles are combined into a concrete aggregate and poured into an organic-shaped mould. The light source itself fulfils the sustainable narrative, using wafer-thin OLED panels made from recycled materials – and providing a soft, and warm natural light that is fully integrated.

Together, the integrated OLED and textured concrete with perforations disperses light uniformly across Bolla for a striking, effervescent glow.



# B O L L A

**Material :** Concrete Cast in Bubble Wrap

**Lead Time :** 12-16 weeks

**Dimensions:** 70cm (h) x 16cm (w)

**Finishes:** Grey and White Concrete

*\* bespoke RAL colour matches available on request*



**Light Source:** OLED Panel

**Temperature :** 3000K

**Voltage:** 220-240v AC or 24v DC

**Brightness (Lumens) :** 200

**Dimmable :** No

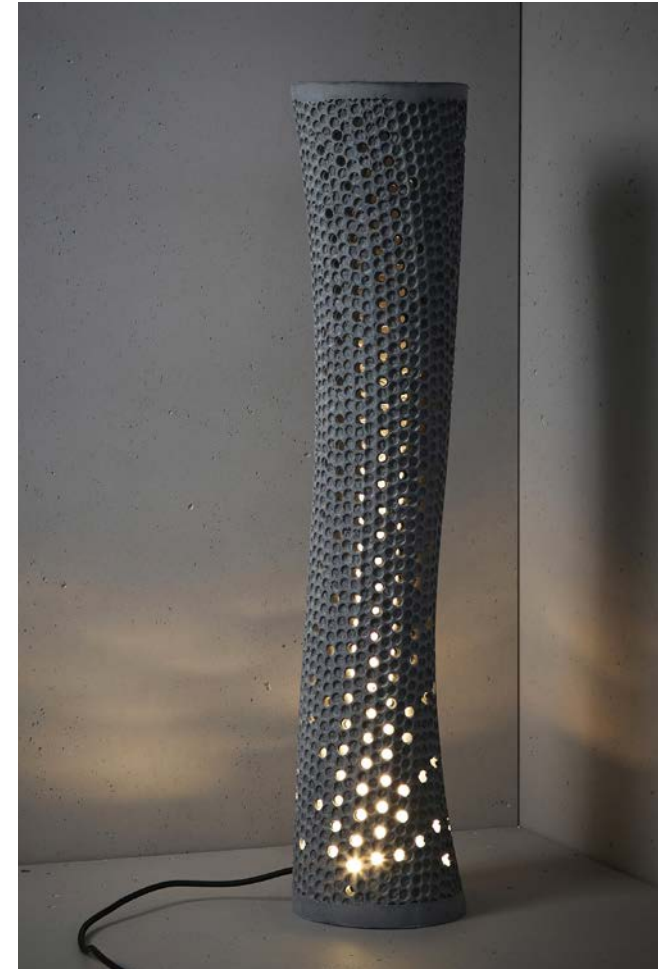
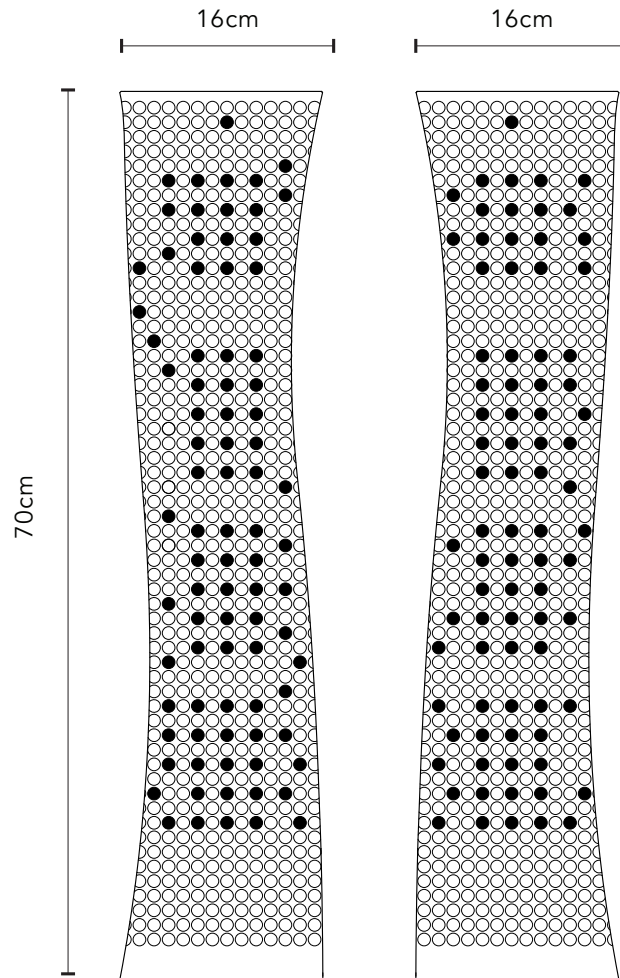

REEF





# R E E F

**Reef** is a wall and table light that can act as a feature in a lobby or be used atop a console table.

Celebrating the sculptural characteristics and form of our disappearing reefs, it combines double-blown and hand-finished glass forms with a dual-parabolic shape. The textured surfaces of each glass form nest seamlessly within the shell - emphasising the jewel-like quality of the product.

The largest globe is illuminated by OLED light panel technology that is sustainable, easy on the eyes, and dimmable.

With its unique shape and resembling artistic jewelry, Reef makes a statement art piece of any space.



# REEF

**Material :** 3D Printing & Handblown Glass

**Lead Time:** 16 Weeks

**Dimensions:** 210mm (h) x 385mm (w)

**Glass Spheres:**

Large : 14cm diameter

Medium : 7.5cm diameter

Small : 5cm diameter

**Finishes:** Bronze, Brushed Brass

*\* bespoke finishes available on request*



**Light Source:** OLED Panel

**Temperature :** 3000K

**Voltage:** 220-240v AC or 24v DC

**Brightness (Lumens) :** 200

**Dimmable :** Yes

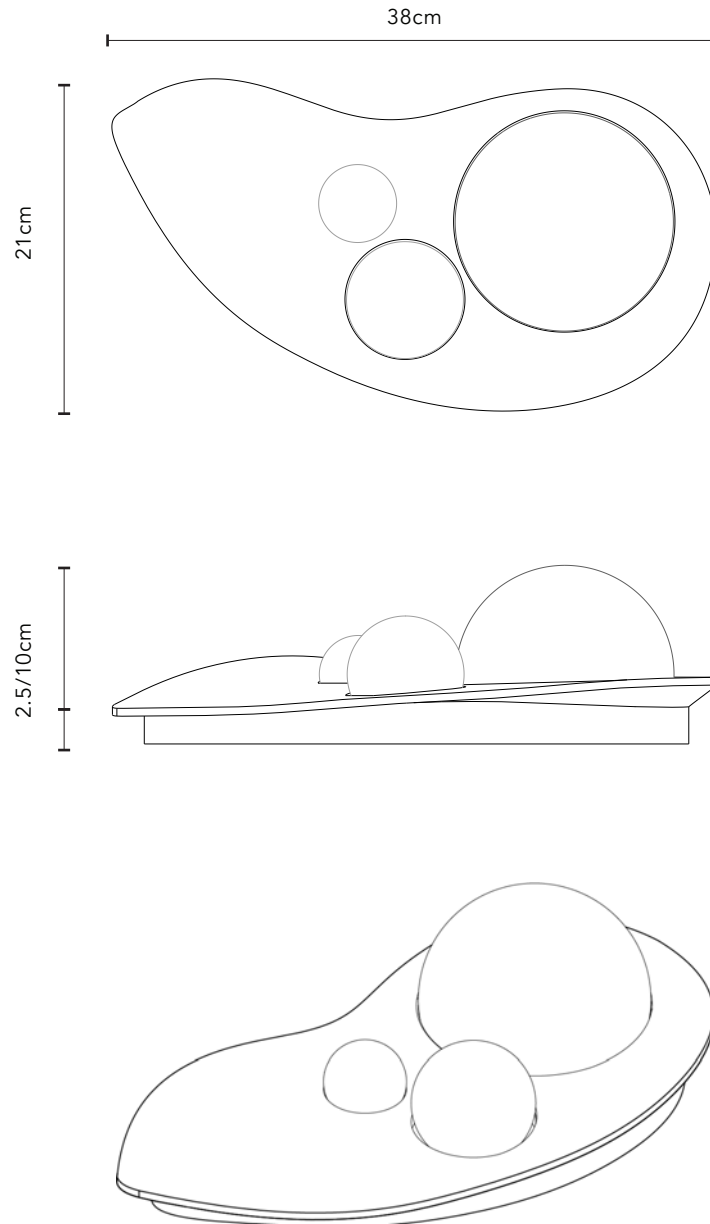

Assembly Drawing

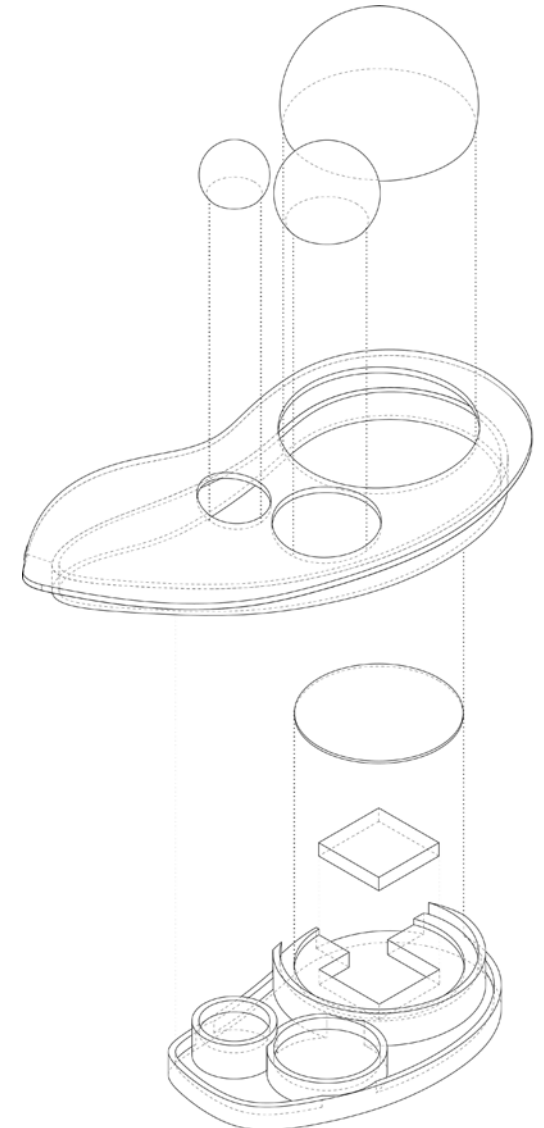



S

# SWIVEL.B ACCESSORIES

**Swivel.B** is a set of decorative bowls made of 3D printed sawdust in collaboration with Forust.

The sculptural form of the bowls has natural, organic curves inviting the user to engage with it in a playful manner.

Once out of the printer, each piece is carefully hand-stained and finished. In this process, there is also the opportunity to finish Swivel in a wide variety of wood species including natural, oak, teak, and walnut or in natural coloured dyes.

The full set of bowls comes in three varying sizes which can be purchased individually or as a trio.





# SWIVEL.B ACCESSORIES

**Material** : 3D Printed Sawdust

**Lead Time** : 10 Weeks

**Dimensions:**

20cm (l) x 17cm (w) x 10cm (h)

18cm (l) x 16cm (w) x 8cm (h)

17cm (l) x 15cm (w) x 6cm (h)

**Finish:**

Natural, Walnut, or Natural Dyes RAL Matched

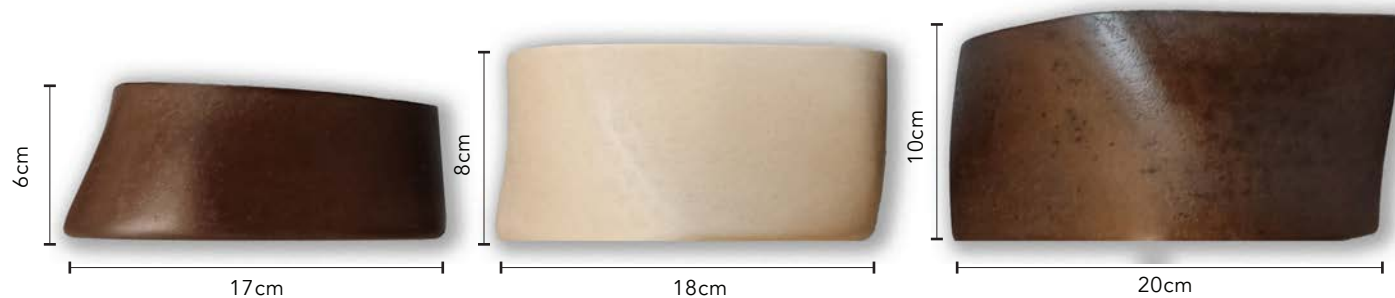

# SWIVEL.B - PLA ACCESSORIES

**Swivel.B**, the set of decorative bowls, is also available in 3D printed BIO-PLA from fermented sugar cane.

Made to order, the Swivel.B are able to be finished to match bespoke colours and durable for indoor or outdoor use due to their inherent UV resistant qualities.





# COCOON NECKLACE

Featuring the scalability of the 3D printed technology, Cocoon Necklace is our first new range of wearable jewelry. It takes its form from our Cocoon light and has natural, organic curves inviting the user to wear the jewelry as a statement to any outfit.

Available in either BIO-PLA finish or from 3D printed sawdust as standard, it makes the perfect gift and is only available on limited release production runs.



## PRICELIST - M

### Contour

Small:	£1,120.00	€1,345.00
Large:	£2,520.00	€3,025.00
Set (S and L):	£3,430.00	€4,120.00

### Kofika POA

### Twine

Small :	£2,730.00	€3,280.00
Large:	£3,185.00	€3,825.00

### Nacre

Step:	£1,005.00	€1,210.00
Stool:	£2,730.00	€3,280.00
Bar:	£3,185.00	€3,825.00
Set of 3:	£6,300.00	€7,560.00

**Cocoon**      £2,555      €3,070

**Bolla**      £2,555      €3,070

**Reef**      £2,555      €3,070

**Nacre.P**      £1,040.00      €1,250.00

### Swivel

Unit Price	£1,390.00	€1,670.00
Set of 3	£3,945.00	€4,735.00

## PRICELIST - S

### Swivel.B Accessories

Set of 3    £1,260.00    €1,515.00

### Cocoon Necklace

£70.00    €85.00

### Note:

- + Set of 3 = a combination set of all 3 sizes
- + All prices excluding VAT
- + All prices excluding delivery and related duties / taxes where applicable
- + Trade discount available to industry
- + Bulk discounts applied on orders of 5+ units



A P P E N D I X  
A B O U T



# T E A M

Trained as architects and urban designers, Sofia Hagen and Lisa Hinderdael pursue a creative approach that explores the relationship of immersive art and biophilic design.



Lisa Hinderdael  
Director

Sofia Hagen  
Director



## SOFIA HAGEN

With a background in architecture and interior design, Sofia focuses on the creative conception of HagenHinderdael's products and installations. An avid public speaker with an engaging personality, she is responsible for the company's business development and marketing strategy.

Whilst launching HagenHinderdael, Sofia practiced as a Senior Design Lead at Heatherwick Studios focusing on the Interior and Product Design for international retail and hospitality projects. Concurrently, she developed expertise on immersive installations in her role as a 3D experience designer for Bompas and Parr. Prior to this she was Design Director at Design Haus Liberty, responsible for the design development of numerous interiors and installation projects in the UK and Europe, as well as establishing the firm's presence in the Chinese market by overseeing a 1.5 million sqft interior architecture project for a leading fashion company in Guangzhou. Before joining DHL, Sofia gained interdisciplinary experience in architecture, interior, exhibition and graphic design at Zaha Hadid Architects, Acme Space and Make, designing commercial, cultural and residential projects in the UK, the Middle East and China.

Sofia trained in architectural design under the aegis of Zaha Hadid at the University of Applied Arts in Vienna, where she graduated with a Masters in Architecture in 2008, followed by a traineeship as interior designer at Odile Decq Architects, Paris.

## LISA HINDERDAEL

Trained in architecture and urban design, Lisa focuses on the delivery of HagenHinderdael's products and installations. With an eye for detail, she is responsible for turning the HagenHinderdael ideas into reality – resolving the technical design of products and project managing installations from concept through to completion. She also oversees the operations and finance at HagenHinderdael and is actively involved in the early stages of conceptual designs to ensure buildability and affordability.

Prior to launching HagenHinderdael, Lisa was Operations Partner at Design Haus Liberty where she was responsible for the running of both the architecture and lighting business. This double outlet allowed her to foster her creative passion for light and installation design and led to her starting her own lighting business inspired by nature and its geometries. Lisa designed the award-winning teardrop light and has managed the design and delivery of several bespoke installations including Simorg at Cardiff Stadium 2018, Dewfall at the Venice Biennale 2016, and Mercury at South Bank Tower 2015. Her luxury lighting designs can be found across several high-end brands including Cartier, the Four Seasons, and the Waldorf Astoria.

Lisa graduated with a Masters in Architecture in Urban Design from London's Bartlett School of Architecture in 2012. She was a traveling scholar to the Veneto in 2010.

# INSTALLATIONS

2023	NODE - Landscape Design in Brixton, London	Landscape Design and curation of NACRE in Node's multi-resi development in London
2022	1212 - HH Pop-up Show in London's Piccadilly Arcade	Exhibition of HH's 3D printed collectibles in Piccadilly Arcade, for Great Portland Estates
	UNFURLED - Gaggenau Showroom London Festival of Architecture	Feature installation at the Gaggenau Showroom London for London Festival of Architecture
	PIPELINE - Contour Public Realm Lake of Constance, Bregenz, Austria	Installation of Contour seating elements along the public realm landscape development
2021	MEADOWS OF CHANGE Arena Square, Wembley Park, London	Feature artwork for Wembley Park with Artistic Statements
	EMBRACE Somerset House, London Design Biennale	Collaboration with Sadie Clayton for the "Design in an Age of Crisis " exhibition
2020	PACA - Fountain of Hygiene Haw Par Music, BODW, Hong Kong	Hand sanitiser design exhibition with Bompas and Parr
	EDEN 2.0 Belgravia, London, UK	Re-arranged EDEN for a permanent location with Artistic Statements for Grosvenor UK&Ireland
	NACRE Dubai Design Week, UAE	Public installation of 3D printed concrete outdoor seating in collaboration with CONCREATIVE
	EDEN Belgravia, London, UK	Public installation with Artistic Statements for Grosvenor UK&Ireland
	PACA - Fountain of Hygiene Design Museum London, UK	Hand sanitiser design exhibition with Bompas and Parr, Dezeen, Christie's and the British Red Cross



NODE



1212



UNFURLED



CONTOUR RO



EDEN 2.0



MEADOWS OF CHANGE



EDEN



EMBRACE



PACA

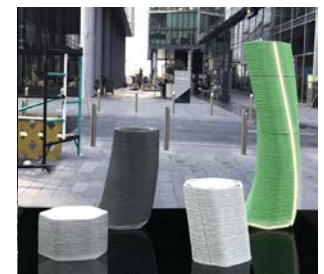

NACRE



# AWARDS & SHOWS

## HH Awards

- 2023 Rossana Orlandi Guiltless Plastic Prize, Finalist : Kofika
- 2021 Dezeen Awards, Longlist Sustainable Design : Cocoon
- 2021 Rossana Orlandi Guiltless Plastic Prize, Finalist : Twine
- 2021 DARC Awards, Shortlist : Bolla
- 2020 LAMP, People's Choice Award : Bolla

## HH Shows

- 2023 Digitising Design, Austrian Cultural Forum, London
- 2023 Guiltless Plastic Prize, Rossana Orlandi, Milan Design Week
- 2023 Conscious Craft, Gaggenau, London
- 2023 Future Build, London
- 2023 Moroso, London
- 2022 EDGE biophilic design showroom, London
- 2022 Material Matters, London Design Festival
- 2022 Rossana Orlandi, Milan Design Week
- 2022 Design in der Lesezone, Vorarlberger Architekturinstitut, Austria
- 2021 HIX Hospitality Design Show, London
- 2021 Minotti, London
- 2021 Planted Cities, London Design Festival
- 2021 Guiltless Plastic Prize, Rossana Orlandi, Milan Design Week
- 2021 Radical Ideas, London Design Biennale London
- 2020 Fountain of Hygiene, Business of Design Week Hong Kong
- 2020 Fountain of Hygiene, Design Museum London

HH



GAGGENAU



MOROSO

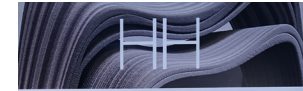

FUTURE BUILD



EDGE



MATERIAL MATTERS LDF

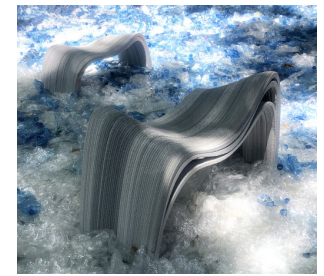

CONTOUR RO



VAI, CONTOUR & COCOON



PLANTED CITIES



TWINE RO

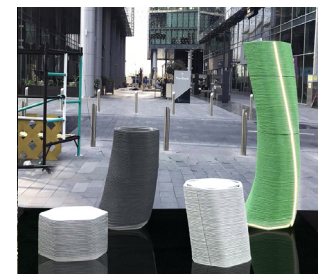

NACRE



# LECTURES & TALKS

- 2023 'Conversations in Craft,' Artefact, London Craft Week, London
- 2023 'Robotic Reincarnation,' Central Saint Martins, London
- 2023 'Digitising Design,' BIG Architects, London
- 2023 'Art meets Ai,' Acrylicize, London
- 2023 'Future Fabrication,' Future Build, London
- 2023 'Metamorphosis,' Moroso, London
- 2023 'Robotic Reincarnation,' UCLA Research Lab, Los Angeles
- 2022 'Material Futures,' Material Matters during London Design Festival
- 2022 'Conscious Craft', Heatherwick Studio, London
- 2022 'Future of Design,' Long Night of Science, Designforum Austria
- 2022 'Design & Maker Culture', Creative Lunch, CampusV, Austria
- 2022 'Digitising Design,' Edge London during London Festival of Architecture
- 2022 'Beyond the Physical,' MAA Guest Live Talk Series
- 2021 'Encounter : An Evening with HagenHinderdael' at Minotti London
- 2021 'Sustainability & Circular Economy', [darc] thoughts at Design London
- 2021 'Functionality in Contemporary Art', with AORA Gallery
- 2021 'Change your Mindset - Placemaking of the Future', HH Podcast for Crestbridge
- 2020 'In Conversation with HH', Planted Uearthed at LondonDesignFestival
- 2019 'Placemaking - How to Deliver Community Value', Future PropTech London
- 2019 'Haptic Pleasures' - panel talk by Bompas and Parr, London
- 2019 Decorative Lighting Design, London Design Festival
- 2019 Creative Industries Hong Kong, London
- 2019 Defining Light of Hospitality, Clerkenwell Design Week, London
- 2019 Financial Times Women's Day, London
- 2018 AIA Viral Voices, New York

HH





# P R E S S

- 2022 FT Weekend, 'A golden age of creativity'
- Elle Decoration, 'Bringing Sexy Back...'
- Vorarlbergerin Magazine, 'VISIONAER'
- Salzburger Nachrichten, '3D Druck Macht Möglich : Möbel aus Beton'
- ArchiExpo Magazine, 'Furniture by HagenHinderdael'
- KUKA, 'A Unique Way to sit thanks to KUKA Robots and 3d Printing'
- The Design Release New York, 'HagenHinderdael at VAI'
- 2021 Kontur Magazine, 'Thinking Outside the Box'
- Apollo Magazine, 'Meadows of Change'
- darc Magazine, 'Designer Focus : Cocoon'
- TimeOut London, 'Meadows of Change'
- Wembley Park Art Trail, 'Meadows of Change'
- Landscape First, 'Eden'
- darc Magazine, 'Designer Focus : Bolla'
- Luxus, 'Using Light to Power Change' & 'Solving Problems with Creativity'
- 2020 Commercial Interior Design Magazine, 'Nacre as Outdoor Furniture'
- Identity Magazine, 'Bubble Wrap Obsession'
- Gulf News, 'Dubai Design Week is Back with Stunning Art Installations'
- Commercial Interior Design Magazine, 'In Pictures : Downtown Design'
- Scale Qatar, 'Waste Not, Want Not'
- Dezeen, 'HagenHinderdael's Bolla Light, Imprinted with Bubble Wrap'
- darc Magazine, 'Women in Lighting'

HH



Telephone boxes have been turned into an art gallery

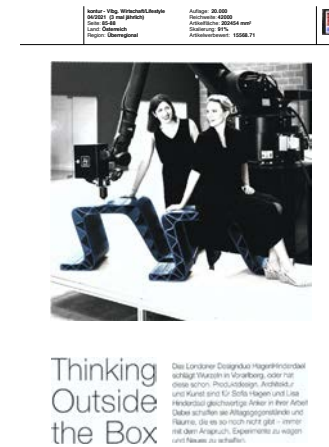



# CLIENTS

## Who We Work With

We target audiences across a varying range of sectors seeking out installations for the public realm alongside feature artwork and light sculptures in the public-facing areas of hotels and high-end residences.

Whether a small scale intervention with impactful change, or a larger scale feature installation - no project is too big or too small for us.

## What They Say About Us

"HagenHinderdael's vision managed to achieve the brief and more than any of us had envisaged. It's beautiful, it's immersive, it's educational. What more can an architectural designer do than to positively change the world around us? To actively effect our mood, our physiology...."

- Zoe Allen, Artistic Statements UK

"We're thrilled to collaborate with the inspiring HagenHinderdael team to create such a positive installation that celebrates nature and biodiversity right in the heart of Belgravia."

- The Grosvenor Group



# THANK YOU

## DISCLAIMER

This document and the ideas incorporated herein, as an instrument of professional service, is the property of HagenHinderdael and is not to be used or reproduced in any manner whatsoever, in whole or in part for any other project without prior written permission from HagenHinderdael Ltd.

For more information please contact:  
[info@hagenhinderdael.com](mailto:info@hagenhinderdael.com)